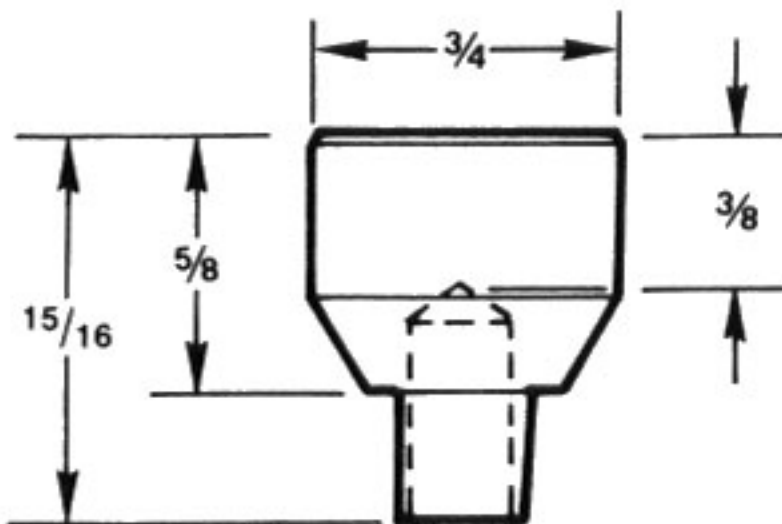
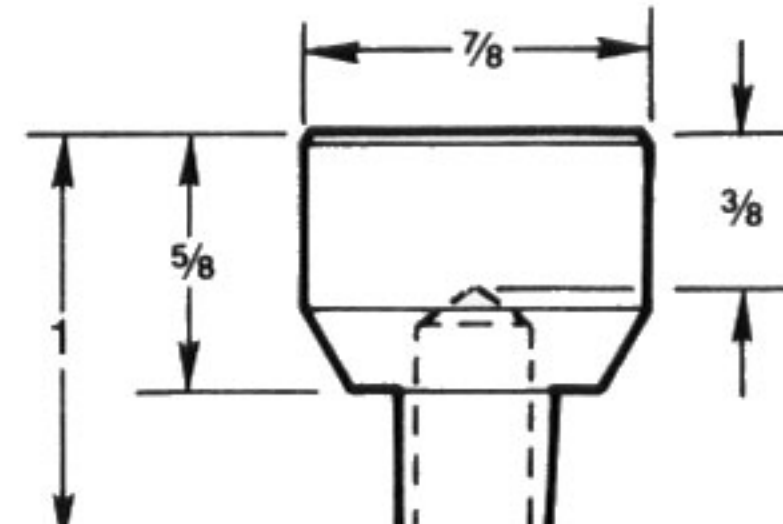
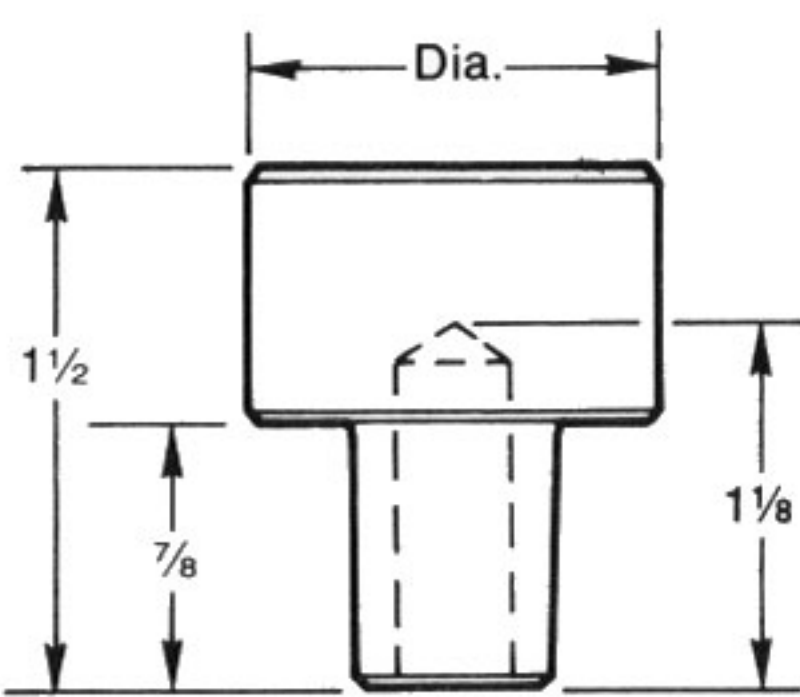
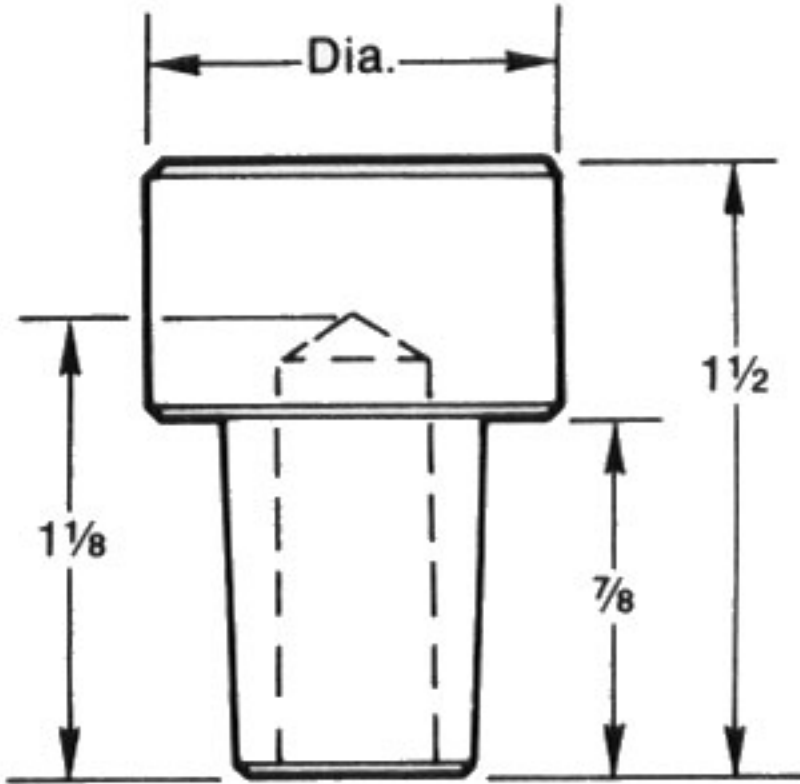
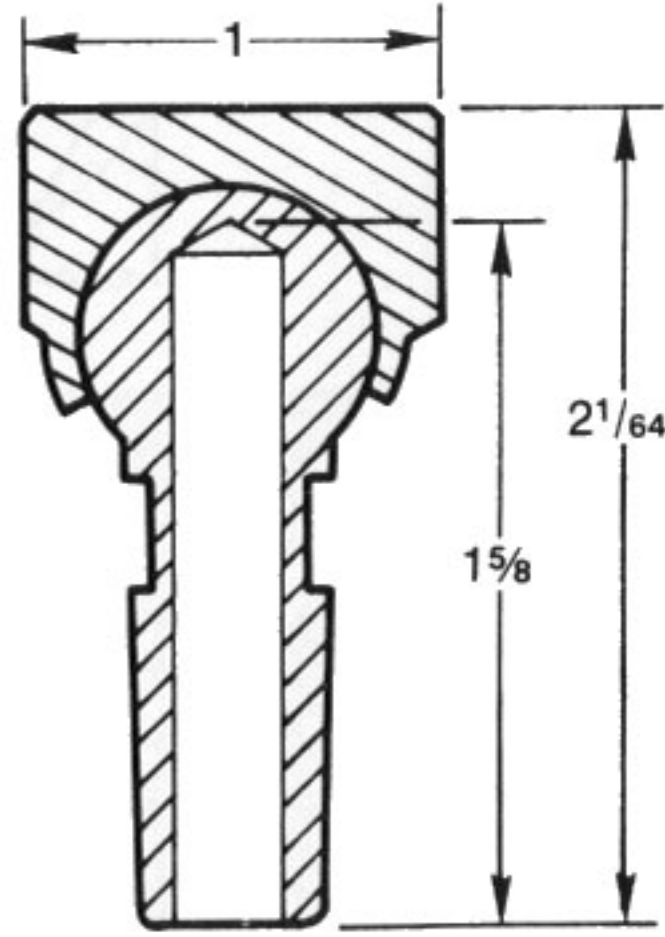
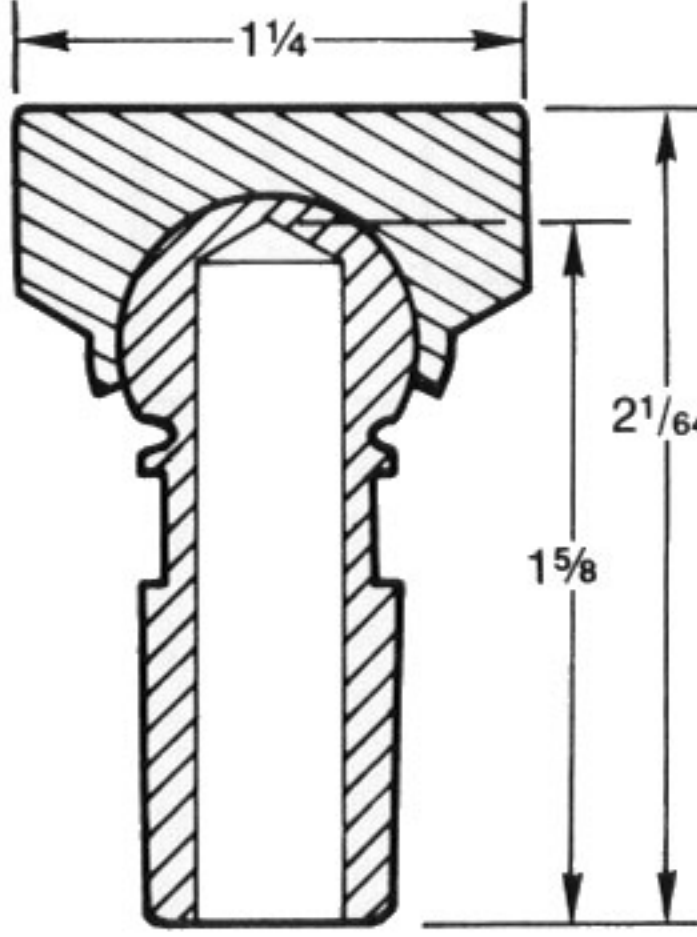
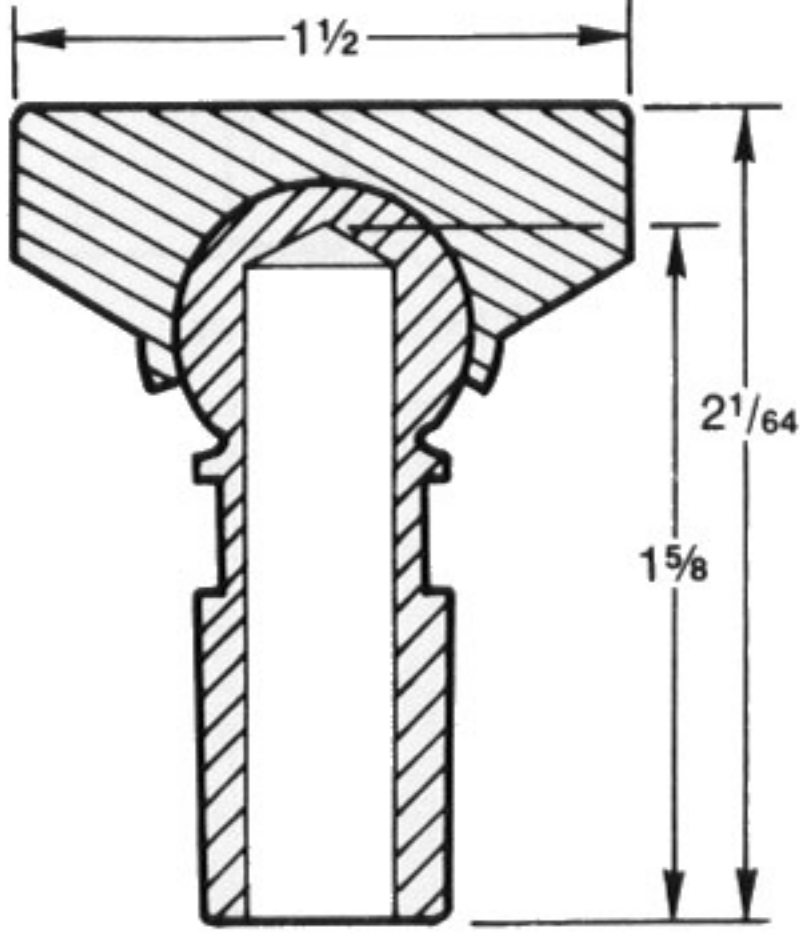

<p style="text-align: center;">BACK-UP INSERTS R.W.M.A. CLASS II ALLOY</p> <p style="text-align: center;">FOR USE WITH NO. 1 AND NO. 2 MORSE TAPER PACIFIC SHANKS.</p> <p style="text-align: center;">REFER TO PAGE 6 FOR MATING SHANKS.</p>	 <p style="text-align: center;">SERIES "1" INSERT</p>	 <p style="text-align: center;">SERIES "2" INSERT</p>
	PART NUMBER - 1-B-2	PART NUMBER - 2-B-2

 <p style="text-align: center;">NO. 1 MORSE TAPER</p>	<p>BACK-UP ELECTRODES R.W.M.A. CLASS II ALLOY</p> <table border="1" style="width: 100%; border-collapse: collapse; margin-top: 10px;"> <thead> <tr style="background-color: #cccccc;"> <th colspan="3">PART NUMBER</th> </tr> <tr style="background-color: #cccccc;"> <th>NO. 1 MORSE TAPER</th> <th>Dia.</th> <th>NO. 2 MORSE TAPER</th> </tr> </thead> <tbody> <tr> <td style="text-align: center;">1B-75-2</td> <td style="text-align: center;">3/4</td> <td style="text-align: center;">2B-75-2</td> </tr> <tr> <td style="text-align: center;">1B-87-2</td> <td style="text-align: center;">7/8</td> <td style="text-align: center;">2B-87-2</td> </tr> <tr> <td style="text-align: center;">1B-100-2</td> <td style="text-align: center;">1"</td> <td style="text-align: center;">2B-100-2</td> </tr> <tr> <td style="text-align: center;">1B-125-2</td> <td style="text-align: center;">1 1/4</td> <td style="text-align: center;">2B-125-2</td> </tr> </tbody> </table>	PART NUMBER			NO. 1 MORSE TAPER	Dia.	NO. 2 MORSE TAPER	1B-75-2	3/4	2B-75-2	1B-87-2	7/8	2B-87-2	1B-100-2	1"	2B-100-2	1B-125-2	1 1/4	2B-125-2	 <p style="text-align: center;">NO. 2 MORSE TAPER</p>
PART NUMBER																				
NO. 1 MORSE TAPER	Dia.	NO. 2 MORSE TAPER																		
1B-75-2	3/4	2B-75-2																		
1B-87-2	7/8	2B-87-2																		
1B-100-2	1"	2B-100-2																		
1B-125-2	1 1/4	2B-125-2																		

SWIVEL HEAD ELECTRODES

		
PART NUMBER	PART NUMBER	PART NUMBER
NO. 1 MORSE TAPER ± 1ST-100-1 NO. 2 MORSE TAPER ± 2ST-100-1	NO. 1 MORSE TAPER ± 1ST-125-1 NO. 2 MORSE TAPER ± 2ST-125-1	NO. 1 MORSE TAPER ± 1ST-150-1 NO. 2 MORSE TAPER ± 2ST-150-1